



**CROSLEY®**

INSTRUCTIONS FOR USE  
**CROSLEY C100**

# IMPORTANT SAFETY INSTRUCTION // CONSIGNES DE SÉCURITÉ IMPORTANTES

	<div style="border: 1px solid black; padding: 5px; margin-bottom: 5px;"> <p><b>CAUTION</b></p> <p><b>DO NOT OPEN</b></p> <p><b>RISK OF ELECTRIC SHOCK</b></p> </div> <p><b>CAUTION:</b> To reduce the risk of electric shock, do not remove any cover. No user-serviceable parts inside. Refer servicing to qualified service personnel only.</p> <div style="border: 1px solid black; padding: 5px; margin-bottom: 5px;"> <p><b>ATTENTION</b></p> <p><b>NE PAS OUVRIR</b></p> <p><b>RISQUE DE CHOC ELECTRIQUE</b></p> </div> <p><b>ATTENTION:</b> Ne démontez pas l'appareil afin de prévenir tout risque de choc électrique. Aucune pièce interne ne peut être réparée par l'utilisateur. Confiez toutes les opérations d'entretien à un technicien qualifié.</p>	
<p>The lightning flash with arrowhead symbol within the equilateral triangle is intended to alert the user to the presence of un-insulated “dangerous voltage” within the product’s enclosure that may be of sufficient magnitude to constitute a risk of electric shock.</p> <p>Le symbole de l'éclair terminé par une flèche situé à l'intérieur d'un triangle équilatéral avertit l'utilisateur de la présence de tension dangereuse non isolée dans l'appareil, dont l'amplitude peut constituer un risque de choc électrique.</p>		<p>The exclamation point within the equilateral triangle is intended to alert the user to the presence of important operation and maintenance (servicing) instructions in the literature accompanying this appliance.</p> <p>Le symbole du point d'exclamation dans un triangle équilatéral vise à avertir l'utilisateur de la présence, dans la documentation accompagnant cet appareil, d'importantes instructions de fonctionnement et d'entretien.</p>

**Caution Marking and rating plate was located at rear enclosure of the apparatus.**

Attention marquage et la plaque signalétique a été situé au boîtier arrière de l'appareil.

<b>WARNING / AVERTISSEMENT</b>
<p>To reduce the risk of fire or electric shock, do not expose this apparatus to rain or moisture. The apparatus shall not be exposed to dripping or splashing and that no objects filled with liquids, such as vases, shall be placed on the apparatus.</p> <p>Pour réduire le risque d'incendie ou de choc électrique, ne pas exposer cet appareil sous la pluie et l'humidité. L'appareil ne doit pas être exposé aux écoulements ou aux éclaboussures et aucun objet ne contenant de liquide, tel qu'un vase, ne doit être placé sur l'objet.</p>

<b>CAUTION / ATTENTION</b>
<p>The mains plug is used as disconnect device. The mains plug of apparatus should not be obstructed or should be easily accessed during intended use.</p> <p>To be completely disconnect the power input, the mains plug of apparatus shall be disconnected from the mains.</p> <p>La prise du secteur est utilise pour déconnecter le système.</p> <p>La prise du secteur ne doit pas être obstruée ou doit être facilement accessible pendant son utilisation.</p> <p>Pour être complètement déconnecté de l'alimentation d'entrée, la prise doit être débranchée du secteur.</p>

# IMPORTANT SAFETY INSTRUCTION

## PLEASE READ CAREFULLY ALL THE FOLLOWING IMPORTANT SAFEGUARDS THAT ARE APPLICABLE TO YOUR EQUIPMENT

1. Read Instructions - All the safety and operating instructions should be read before the product is operated.
2. Retain instructions - The safety and operating instructions should be retained for future reference.
3. Heed Warnings - All warnings on the product and in the operating Instructions should be adhered to.
4. Follow Instructions - All operating and use instructions should be followed.
5. Cleaning - Unplug this product from the wall outlet before cleaning. Do not use liquid cleaners or aerosol cleaners. Use a damp cloth for cleaning.
6. Attachments - Do not use attachments not recommended by the product manufacturer as they may cause hazards.
7. Water and Moisture - Do not use this product near water - for example, near a bath tub, wash bowl, kitchen sink, or laundry tub; in a wet basement; or near a swimming pool; and the like.
8. A product and cart combination should be moved with care. Quick stops, excessive force, and uneven surfaces may cause the product and cart combination to overturn.
9. Ventilation - Slots and openings in the cabinet are provided for ventilation and to ensure reliable operation of the product and to protect it from overheating, and these openings must not be blocked or covered. The openings should never be blocked by placing the product on a bed, sofa, rug, or other similar surface. This product should not be placed in a built-in installation such as a bookcase or rack unless proper ventilation is provided or the manufacturer's instructions have been adhered to.
10. Power Sources - This product should be operated only from the type of power source indicated on the marking label, if you are not sure of the type of power supply to your home. Consult your product dealer or local power company. For products intended to operate from battery power, or other sources, refer to the operating instructions.
11. Grounding or Polarization - This product may be equipped with a polarized alternating-current line plug (a plug having one blade wider than the other). This plug will fit into the power outlet only one way. This is a safety feature. If you are unable to insert the plug fully into the outlet try reversing the plug. If the plug should still fail to fit, contact your electrician to replace your obsolete outlet. Do not defeat the safety purpose of the polarized plug.
12. Power - Cord Protection - Power - supply cords should be routed so that they are not likely to be walked on or pinched by items placed upon or against them, paying particular attention to cords at plugs, convenience receptacles, and the point where they exit from the product.
13. Lightning - For added protection for this product during a lightning storm, or when it is left unattended and unused for long periods of time, unplug it from the wall outlet and disconnect the antenna or cable system. This will prevent damage to the product due to lightning and power - line surges.
14. Power Lines - An outside antenna system should not be located in the vicinity of overhead power lines or other electric light or power circuits, or where it can fall into such power lines or circuits. When installing an outside antenna system, extreme care should be taken to keep from touching such power lines or circuits as contact with them might be fatal.
15. Overloading - Do not overload wall outlets, extension cords, or integral convenience receptacles as this can result in a risk of fire or electric shock.
16. Object and Liquid Entry - Never push objects of any kind into this product through openings as they may touch dangerous voltage points or short-out parts that could result in a fire or electric shock. Never spill liquid of any kind on the product.
17. Servicing - Do not attempt to service this product yourself as opening or removing covers may expose you to dangerous voltage or other hazards. Refer all servicing to qualified service personnel.
18. Damage Requiring Service - Unplug this product from the wall outlet and refer servicing to qualified service personnel under the following conditions;
  - a. When the power-supply cord or plug is damaged.
  - b. If liquid has been spilled, or objects have fallen into the product.
  - c. If the product has been exposed to rain or water.
  - d. If the product does not operate normally by following the operating instructions. Adjust only those controls that are covered by the operating instructions as an improper adjustment of other controls may result in damage and will often require extensive work by a qualified technician to restore the product to its normal operation.
  - e. If the product has been dropped or damaged in any way.
  - f. When the product exhibits a distinct change in performance - this indicates a need for service.
19. Replacement Parts - When replacement parts are required, be sure the service technician has used replacement parts specified by the manufacturer or have the same characteristics as the original part. Unauthorized substitutions may result in fire, electric shock, or other hazards.
20. Safety Check - Upon completion of any service or repairs to this product, ask the service technician to perform safety checks to determine that the product is in proper operating condition.
21. Wall or ceiling Mounting - The product should be mounted to a wall or ceiling only as recommended by the manufacturer.
22. Heat - The product should be situated away from heat sources such as radiators, heat registers, stoves, or other products (including amplifiers) that produce heat.

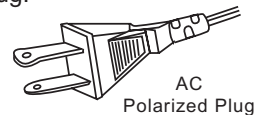

**WARNING:** Changes or modifications to this unit not expressly approved by the party responsible for compliance could void the user's authority to operate the equipment.

**NOTE:** This equipment has been tested and found to comply with the limits for a Class B digital device, pursuant to Part 15 of the FCC Rules. These limits are designed to provide reasonable protection against harmful interference in a residential installation. This equipment generates, uses, and can radiate radio frequency energy and, if not installed and used in accordance with the instructions, may cause harmful interference to radio communications. However, there is no guarantee that interference will not occur in a particular installation. If this equipment does cause harmful interference to radio or television reception, which can be determined by turning the equipment off and on, the user is encouraged to try to correct the interference by one or more of the following measures:

- Reorient or relocate the receiving antenna.
- Increase the separation between the equipment and receiver.
- Connect the equipment into a circuit different from that to which the receiver is connected.
- Consult the dealer or an experienced radio TV technician for help.

# CONTROLS

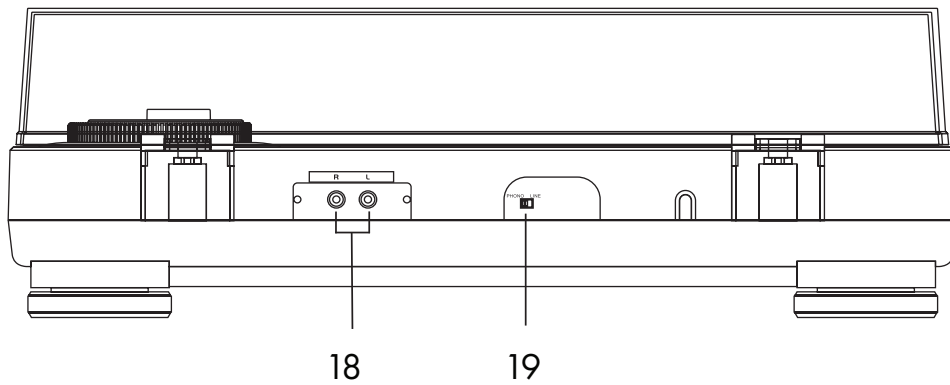
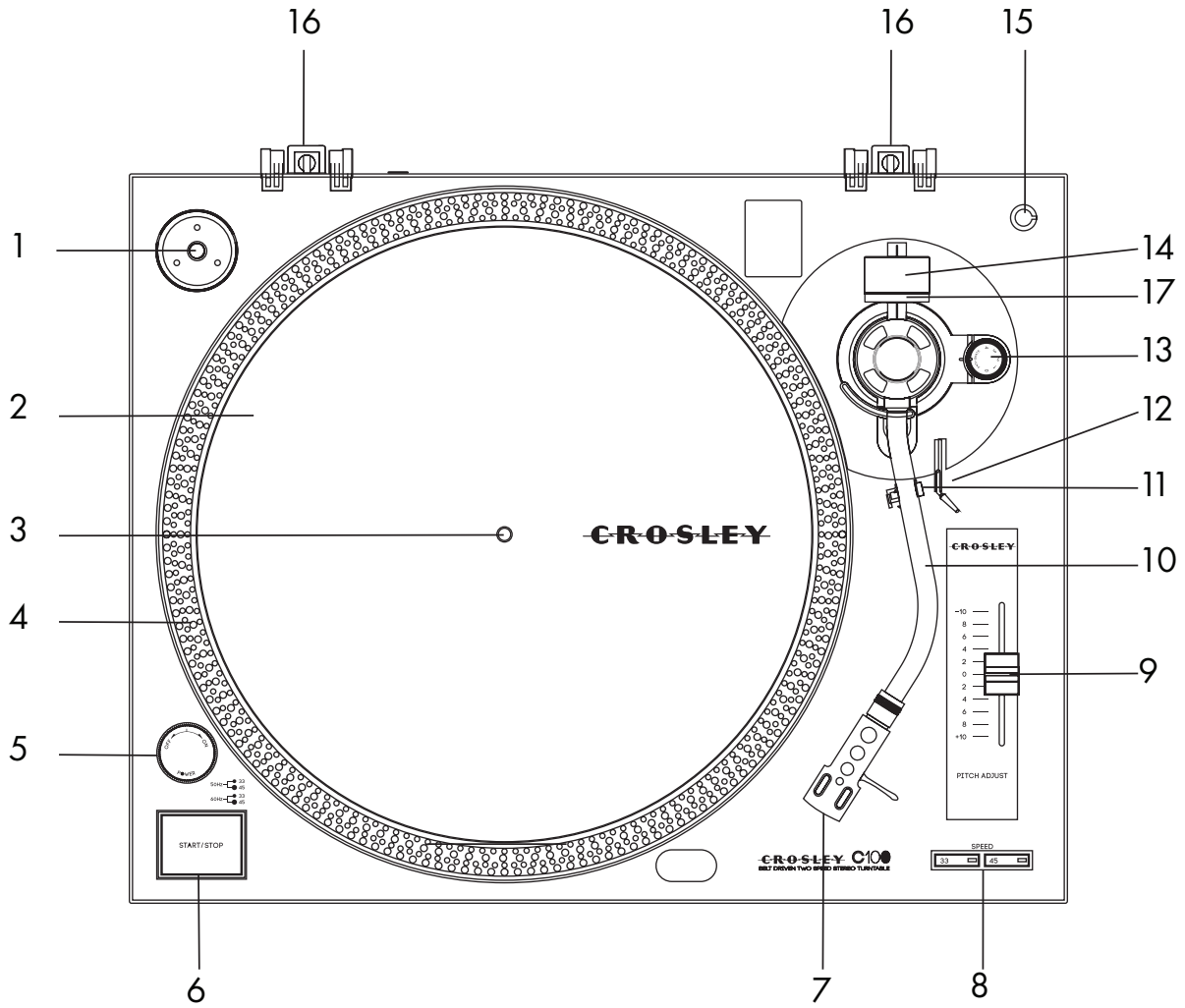

- |    |                      |    |                                 |
|----|----------------------|----|---------------------------------|
| 1  | 45 RPM Adaptor       | 11 | Tonearm Rest and Hold Down Clip |
| 2  | Turntable Platter    | 12 | Cue Lever                       |
| 3  | Spindle              | 13 | Anti-skate Knob                 |
| 4  | Strobe Dots          | 14 | Counterweight                   |
| 5  | On/Off Switch        | 15 | Spare Headshell Holder          |
| 6  | Start/Stop Button    | 16 | Hinges for Turntable Lid        |
| 7  | Headshell            | 17 | Downforce Scale                 |
| 8  | Speed Select Buttons | 18 | Line out/Phono Jack             |
| 9  | Pitch Control        | 19 | Line out/Phono Switch           |
| 10 | Tonearm              |    |                                 |

# SPECIFICATIONS

## GENERAL

Power supply	AC 120V~60Hz
Power consumption	8 Watts
Dimension	450(W) x 350(D) x 145(H) mm
Weight	4.55 Kgs

## TURNTABLE

Driving Method	Belt driven
Speeds	33 1/3 and 45RPM
Supplied stylus	AT3600L
Stylus Pressure	3.5g
Anti-skate range	0~4

*\*note: design and specifications are subject to change without notice*

# GETTING STARTED

## INCLUDED IN THE PACKAGE:

- 1 Turntable platter
- 2 Slip mat
- 3 Turntable lid
- 4 45 RPM adaptor
- 5 Counterweight
- 6 Headshell
- 7 User Manual

### **Important notes:**

- 1 Do not connect the AC power plug before assembly has been completed.
- 2 Before turning the power on, make sure once again all the connections settings are correct. Always turn off the power when connecting or disconnecting.
- 3 Read this manual carefully before using the unit. Be sure to store the manual in a safe place for future reference.
- 4 Do not place the unit in a location where it will be exposed to direct sunlight or near a heating appliance.
- 5 Do not place the unit in a location where there is high humidity or a lot of dust.
- 6 The selected location should be free from vibration and stable. Cartridge may pick up slight vibrations from the speakers or the floor.

## GETTING PREPARED

- 1 Remove the turntable from the box and remove the packaging.
- 2 Put the 45-rpm adaptor into its holder.
- 3 Set the turntable platter onto the center spindle.
  - a. Once the turntable platter is in place rotate the platter so that the large window is that the top right corner, allowing you to access the pulley on the drive motor as shown below.

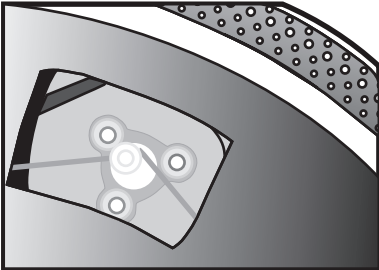

- b. Carefully grab the drive belt, (already attached to the underside of the turntable platter), and place it around the pulley on the drive motor.
- 4 Put the slip mat over the platter.
- 5 Insert the headshell into the front end of the tonearm, and then turn the locknut clockwise with the headshell firmly held horizontally.
- 6 Slide counterweight onto tonearm and twist it lightly onto the rear shaft of the tonearm.
- 7 Adjustment of horizontal "zero" balance and stylus pressure:
  - a. Remove the stylus protector from the headshell and avoid touching the stylus tip during the adjustment.
  - b. Lower the tonearm using the cue lever.
  - c. Using the cue level, lower the tonearm to its lowest position.
  - d. Rotate the counterweight towards the front of the turntable until the tonearm is balanced (floats freely).
  - e. Return the tonearm back to the tonearm rest.
  - f. Hold the counterweight stationary with one hand and rotate only the downforce scale until the "0" on the scale lines up with the centerline marked along the top of the tone arm.
  - g. Rotate the counterweight including the downforce scale counter-clockwise (as seen from the front of the turntable) until the scale shows the value corresponding to the pressure required for stylus.

NOTE: The recommended downforce for the factory fitted cartridge is 3.5g
- 8 Set the anti-skating control knob to the same value as the stylus pressure.
- 9 Install the turntable lid to the hinges.
- 10 Place the turntable on a flat, level surface. To help ensure the turntable is level, the height of the legs can be adjusted by rotating them.

## INSTALLATION OF NEW CARTRIDGE

Your unit comes pre-installed with cartridge mounted to the headshell. When installing a new or different cartridge, refer to the installation instructions of that cartridge. During installation attach the stylus protector to guard the stylus tip from damage.

- a. Connect the lead wires to the cartridge terminals. The terminals of most cartridges are color coded.

Connect each lead wire to the terminal of the same color.

White (L+) ..... Left channel +

Blue (L-) ..... Left channel -

Red (R+) ..... Right channel +

Green (R-) ..... Right channel -

- b. Install the cartridge to the headshell and lightly tighten screws provided with the cartridge.
  - c. Use a cartridge alignment tool (not included) to ensure the new cartridge is properly aligned. If adjustments need to be made, loosen the cartridge screws and gently rotate the cartridge and recheck until correct according to your cartridge alignment tool. Once correct, fully tighten the cartridge screws.
- NOTE: See instructions included with cartridge alignment tool on how to correctly align your cartridge.

## **TURNTABLE OPERATION**

- 1 Turn the On/Off Switch clockwise to turn on the power, the speed indicator light, which is located beneath the On/Off switch, will light up.
- 2 Place a record on the slip mat. When playing a 45-rpm record with a large center hole, place the 45-rpm adapter on the center spindle.
- 3 Set the speed to match the record.
- 4 Remove the stylus protector from the stylus, and release the lock clip from the Tonearm Rest.
- 5 Set the cueing lever to the up position.
- 6 Press the Start/Stop Button, the turntable platter will start to rotate.
- 7 Move the tonearm over the desired groove.
- 8 Set the cueing lever to the down position, the tonearm will descend slowly onto the record and begin playing.
- 9 When play is finished, raise the cueing lever, move the tonearm onto the Tonearm clamp.
- 10 Press the Start/Stop Button to stop the platter from rotating. Turn the On/Off Switch counterclockwise to turn off the power.

## **ADJUSTING THE SPEED**

- As long as the pitch control is in center "detent" click position, the turntable is operated at selected speed.
- The speed can be increased or decreased by 10% by the pitch control.
- When the speed is correct for the setting, the strobe dots will appear to stand still while the turntable is spinning. If the speed is too fast, the dots will appear to move clockwise. If the speed is too slow, the dots will counter-clockwise.

## **TURNTABLE MAINTENANCE**

- 1 Clean the stylus periodically with a soft brush to get rid of the dust.
- 2 When playback sound becomes distorted or noisy, check the stylus. If the stylus is worn out, replace it with a new one.
- 3 Clean the turntable lid and turntable cabinet a soft microfiber cloth periodically to keep the turntable clean.
- 4 Use water to aid the cleaning process if necessary. Do not use cleanser that contains alcohol, benzine etc. which might damage the paint and finish of the turntable.



# TROUBLESHOOTING

Crosley turntables are manufactured to the highest standards and undergo strict quality controls before leaving the factory. Faults that may possibly occur are not necessarily due to material or production faults but can sometimes be caused by incorrect use or unfortunate circumstances. Therefore the following list of common fault symptoms is included.

## **The platter doesn't turn although the unit is switched on:**

- The unit is not connected to the main power supply.
- No power at the outlet.
- Drive belt is not installed or has slipped off.

## **No signal through one or other channel or both channels:**

- Correct input not selected at amplifier.
- Amplifier not switched on.
- Amplifier or speakers muted.
- No connection to the speakers.
- No connection between turntable and amplifier.
- Wire leads not connected the cartridge.

## **Strong hum on phono input:**

- No ground connection from cartridge, arm, or arm cable to amplifier or ground loop.
- Turntable too close to speakers.

## **Distorted or inconsistent sound from one or both channels:**

- Turntable is connected to wrong input of amplifier.
- Needle or cantilever damaged.
- Drive belt overstretched or dirty.
- Platter bearing without oil, dirty or damaged.
- Dust on stylus.
- MM/MC switch on preamplifier set incorrectly.

## **LIMITED MANUFACTURERS WARRANTY**

Crosley Radio, Inc. warrants the product to be free from defects in material and workmanship under normal use for a period of one year from the original date of purchase. This warranty is not transferable. If the product is determined to be defective during the warranty period, the unit will be repaired or replaced at Crosley Radio's sole discretion. This warranty covers manufacturing defects and normal consumer use and does NOT cover damage or failure as a result of abuse, accident, alterations, misuse, neglect, abnormal wear and tear, inadequate maintenance, commercial or unreasonable use, damage caused by power surges, mishandling, accident, acts of God or attempted repair by an unauthorized service agent. Also not covered are cosmetic damages, cords and antennas.

Should this product fail to function in a satisfactory manner, it is best to first contact our technical support team for assistance to ensure it is being operated properly.

## **TECH SUPPORT AND PRODUCT QUESTIONS**

CALL TOLL FREE: **1.888.CROSLEY** (1.888.276.7539)

If it is indeed determined that the unit is no longer operational, please contact the retailer from which it was purchased. In many cases, your retailer will be able to provide a replacement unit at no charge within the scope of their return policy. If the retail return period has expired, please contact Crosley Radio directly to participate in the one year protection program.

## **CROSLEY 1 YEAR WARRANTY PROGRAM**

CALL TOLL FREE: **1.800.926.7801**

You will need to contact our offices M-F 8am-5pm EST to obtain an RA (Return Authorization) Number. You will be instructed to send the unit (at your cost) to our offices in its original packaging (or reasonable substitute to prevent damage.) You will need to clearly mark your RA number on the outside packaging and include the original sales receipt (or a copy) indicating date of purchase, amount paid, and place of purchase. You will also need to include your full name, shipping address and daytime contact number. You will be instructed to include a check or money order for any applicable return shipping and handling fees. A Crosley advisor will confirm the fees associated with your product's shipping size/weight. Returned products will not be shipped to PO Boxes.

Crosley Radio will not be responsible for delays or unprocessed claims resulting from a purchaser's failure to provide any or all of the necessary information.

There are no express warranties except as listed above.

The purchaser's bill of sale is the only proof of warranty entitlement.

This warranty gives the purchaser specified legal rights in addition to any rights which may vary from state to state.

In accordance with the "Moss-Magnuson Warranty Act" of July 10, 1975, this is termed a "limited warranty" which in no way compromises Crosley Radio's high standards of quality and workmanship.



**CROSLLEY®**